

SNIPER X2RS REMOTE START MODULE

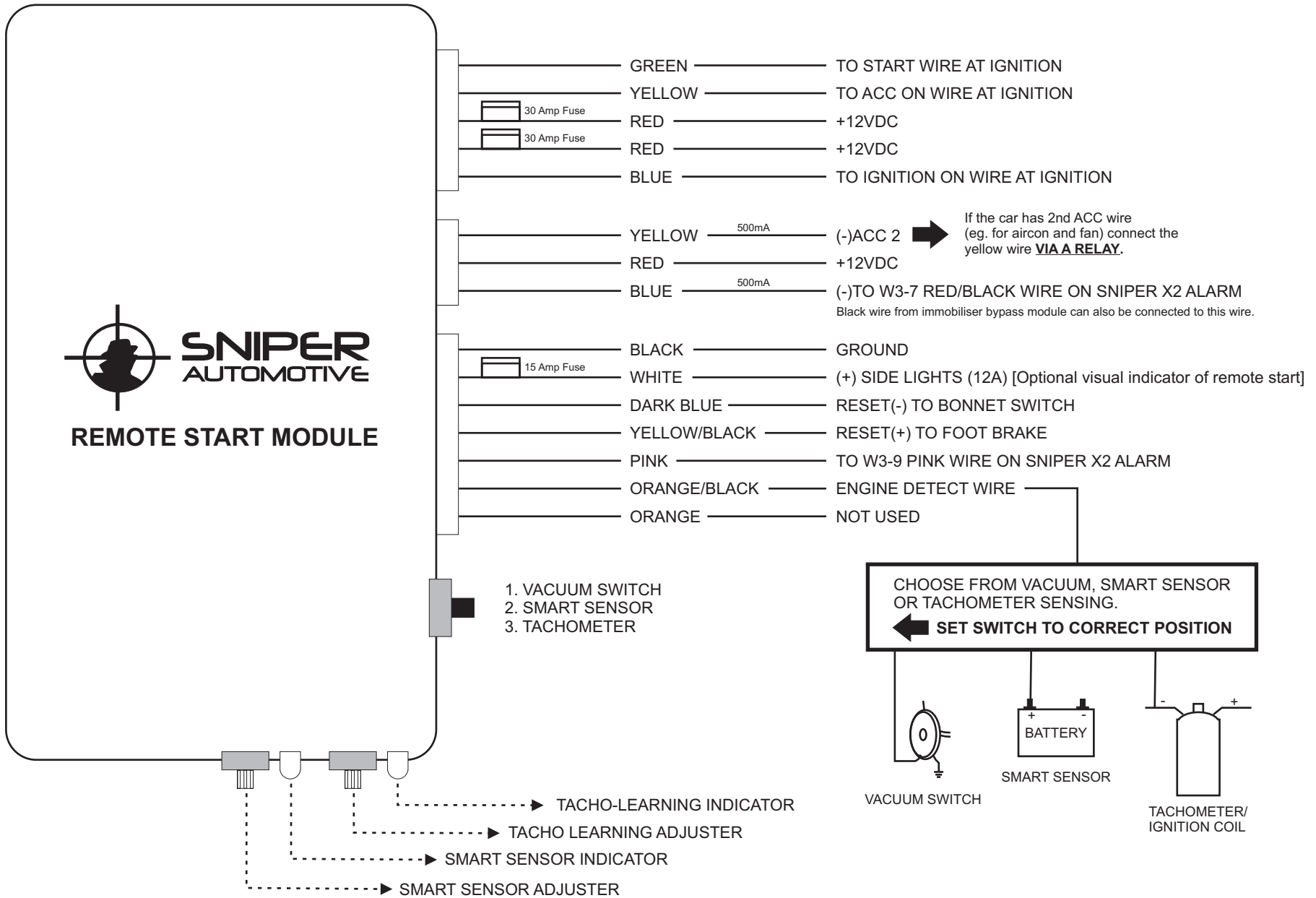

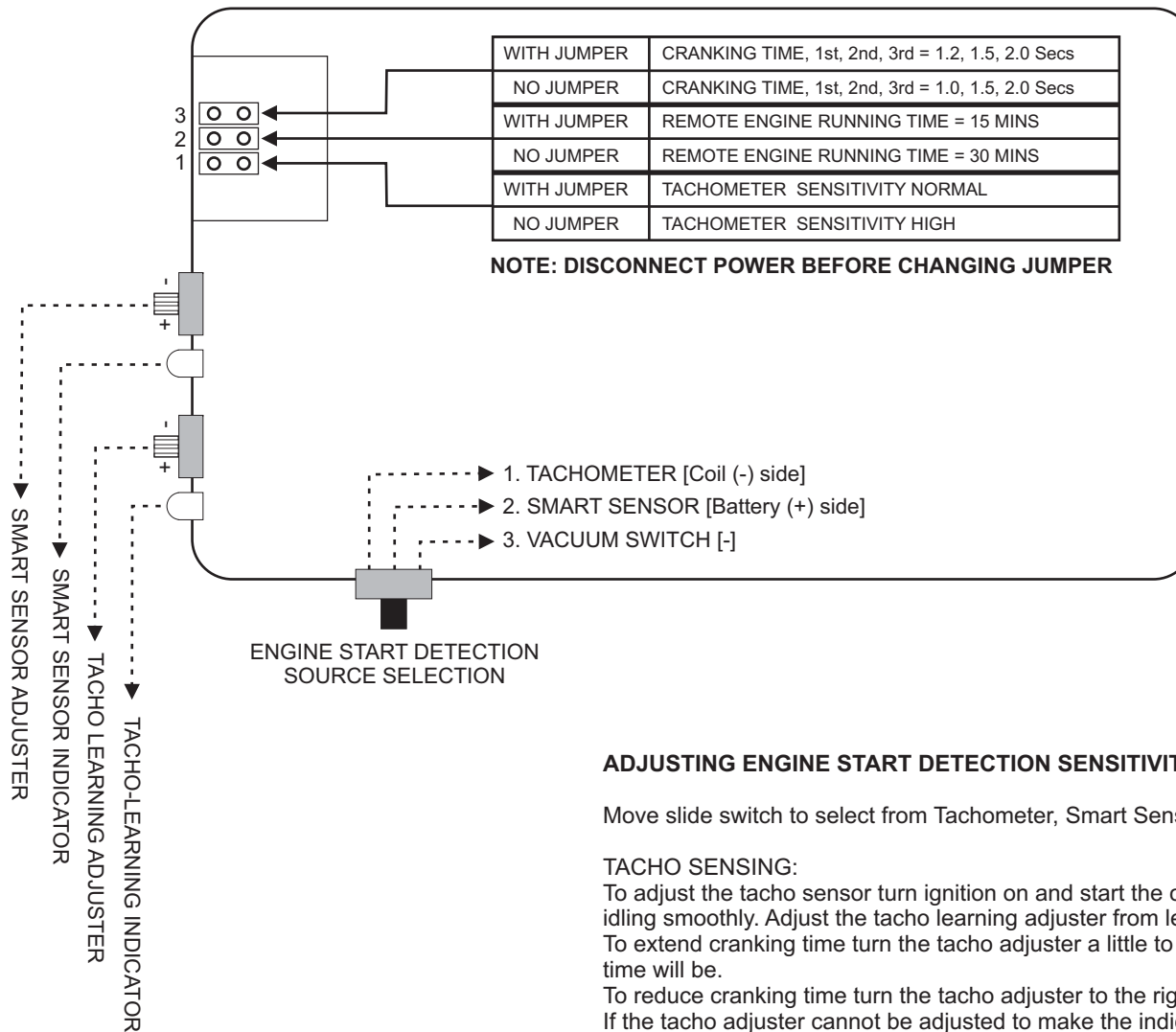

ADJUSTING ENGINE START DETECTION SENSITIVITY

Move slide switch to select from Tachometer, Smart Sensor or Vacuum switch for engine start detection.

TACHO SENSING:

To adjust the tacho sensor turn ignition on and start the car, press and release the accelerator until the car is idling smoothly. Adjust the tacho learning adjuster from left to right until the tacho learning indicator just turns on. To extend cranking time turn the tacho adjuster a little to the left, the further left it is turned the longer the cranking time will be.

To reduce cranking time turn the tacho adjuster to the right.

If the tacho adjuster cannot be adjusted to make the indicator turn on remove jumper 1 to increase the sensitivity of the sensor.

SMART SENSING:

Adjust the smart sensor adjuster from left to right until the following is true:

1. When ignition is on and engine is off the smart sensor indicator should not be on or flash.
2. When ignition is on and engine is idling, the smart sensor indicator must be on (flash).